

PVC-U CHECK VALVES - BALL SERIES

VÁLVULAS ANTI-RETORNO PVC-U - SERIE BOLA



Sizes	Solvent cement D20 - D110 (DN15 - DN100) Threaded 1/2" - 4"	
Standards	Solvent socket - Metric, British standard, ASTM, JIS Threaded - BSP, NPT	EN ISO 1452, EN ISO 15493, BS 4346-1, ASTM D 2467, JIS K 6743 ISO 228-1, ASTM D 2464
Working pressure	@ 20°C (73°F) D20-D63 (1/2" - 2"): PN 16 (240 psi) D75 - D110 (2 1/2" - 4"): PN 10 (150 psi)	
Minimum return pressure	0,2 bar (3 psi) Minimal downstream pressure to keep the valve closed in horizontal position. Presión mínima aguas abajo para mantener la válvula cerrada en caso de instalación horizontal.	
Materials	O-rings: EPDM / FPM	
Characteristics	<ul style="list-style-type: none"> • Completely made in plastic - corrosion free. • 100% factory tested. • Excellent flow rate. • Easy installation and maintenance. • May be used either vertically and horizontally. • Available in PVC-U and Corzan® PVC-C. • Resistance to many inorganic chemicals. • Excellent flow characteristics. 	<ul style="list-style-type: none"> • Fabricada completamente en plástico - libre de corrosión. • Probadas al 100% en fábrica. • Excelente coeficiente de caudal. • Fácil instalación y mantenimiento. • Se pueden usar indistintamente verticalmente o horizontalmente. • Disponibles en PVC-U y Corzan® PVC-C. • Resistencia a múltiples sustancias químicas inorgánicas. • Excelentes características de conducción.
Certifications / regulations	Check valve design regulation - ISO 16137:2006	

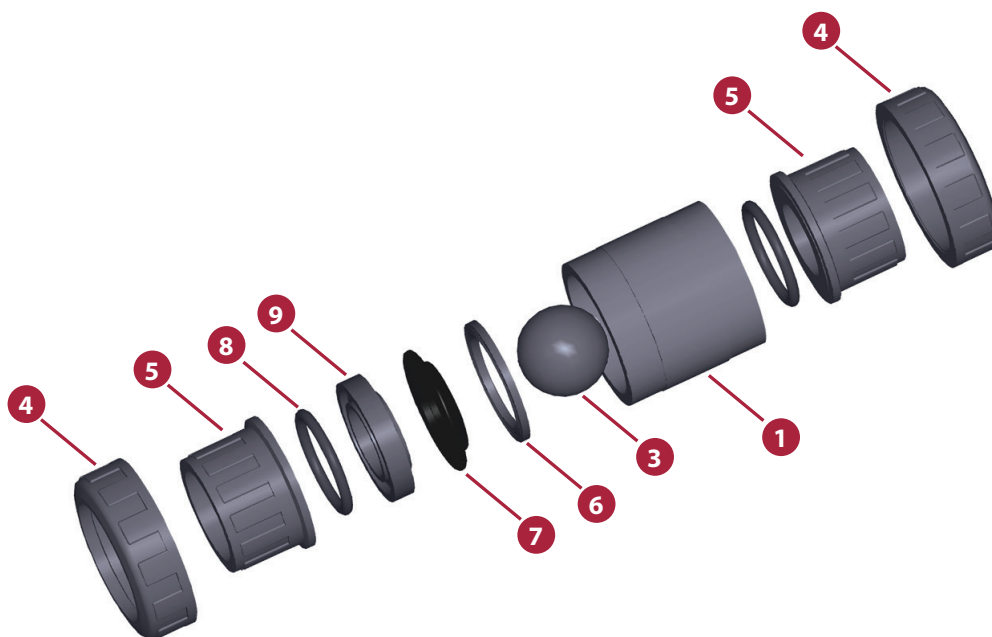
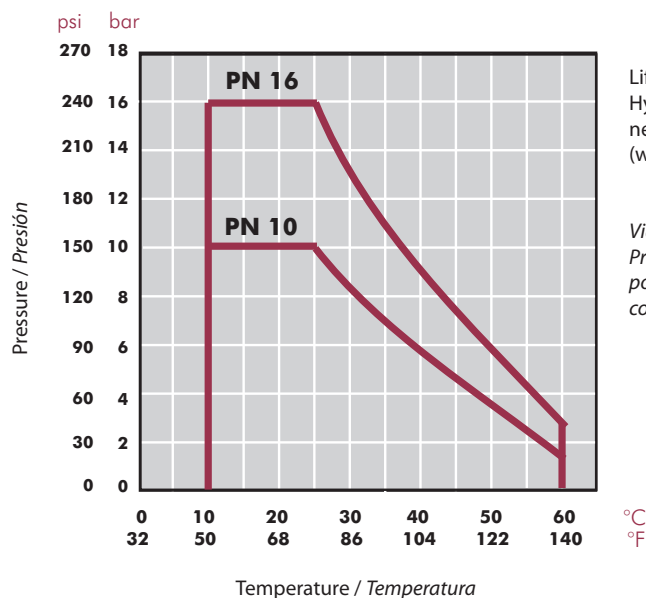

FIG.	Parts	Despiece	Material
1	Body	Cuerpo	PVC-U
3	Ball	Bola	PVC-U
4	Union nut	Tuerca	PVC-U
5	End connector	Manguito enlace	PVC-U
6	Closing ring	Anillo de cierre	PVC-U
7	Body o-ring	Junta cuerpo	EPDM / FPM
8	End connector o-ring	Junta manguito	EPDM / FPM
9	Seal-carrier	Portajuntas	PVC-U

PRESSURE / TEMPERATURE GRAPH
DIAGRAMA PRESIÓN / TEMPERATURA



Life: 25 years
 Hydrostatic maximum pressure a component may withstand in continuous service (without overpressure)

Vida útil: 25 años
 Presión hidrostática máxima que un componente es capaz de soportar en servicio continuo (sin sobrepresión)

PRESSURE LOSS DIAGRAM
DIAGRAMA DE PÉRDIDAS DE CARGA

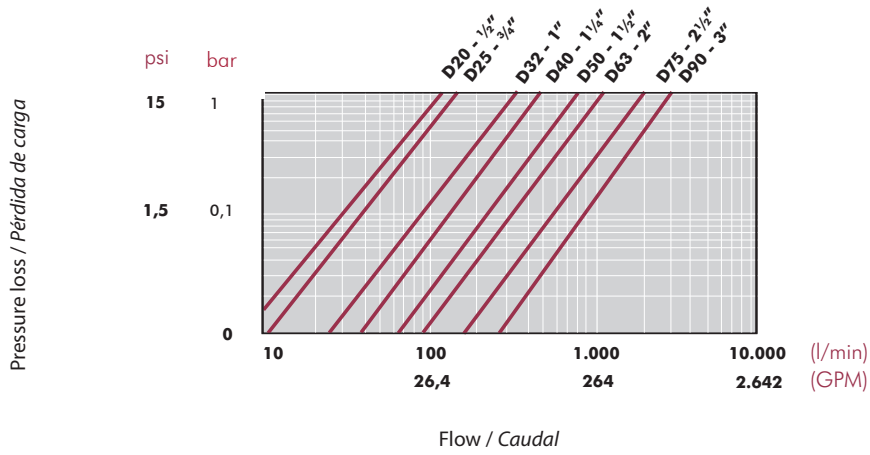

RELATIVE FLOW
FLUJO RELATIVO

D	20-1/2"	25-3/4"	32-1"	40-1 1/4"	50-1 1/2"	63-2"	75-2 1/2"	90-3"
DN	15	20	25	32	40	50	65	80
Kv ₁₀₀	99	128	308	453	795	1040	1932	2754
Cv	7	9	22	32	56	73	135	193

$Cv = Kv_{100} / 14,28$
 Kv_{100} (l/min, $\Delta p = 1$ bar)
 Cv (GPM, $\Delta p = 1$ psi)

Open
Abierto

Closed
Cerrado

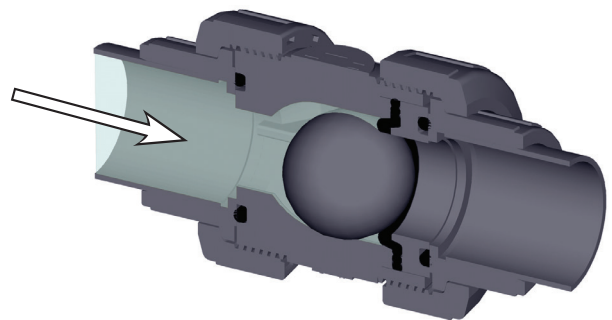
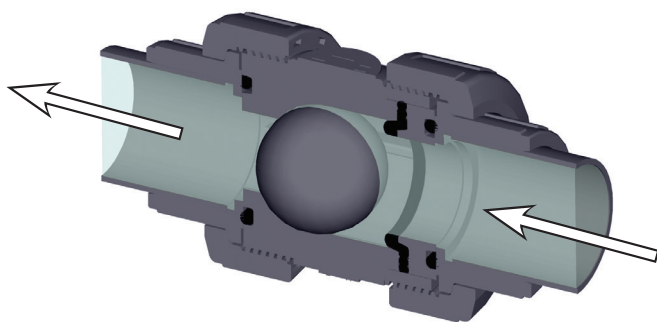

ASSEMBLY INSTRUCTIONS

Solvent socket or threaded unions

Loosen the valve union nuts (4) and separate these and the end connectors (5) from the valve body. Pass the pipe through the nuts and then place the bushes over the end of the pipe. The socket unions should be glued onto the pipe using a PVC-U or PVC-C adhesive and pressure should not be applied to the system until a drying period of at least 1 hour per bar of working pressure has elapsed. In the case of threaded unions, PTFE tape should be applied to the male threads. The pipes can now be attached to the valve by hand tightening down the nuts.

INSTRUCCIONES DE MONTAJE

Uniones encoladas o roscadas

Afloje las tuercas (4) de la válvula y sepárelas de los manguitos (5). Introduzca las tuercas en los tubos y a continuación fije los manguitos en los extremos del tubo. Las uniones encoladas se realizarán con un adhesivo para tubos de PVC-U o PVC-C rígido y no se aplicará presión hasta transcurridas al menos 1 hora por bar. En las uniones roscadas se colocará cinta de PTFE en las roscas macho. A continuación ya podrá colocarse la válvula entre los manguitos y apretar a mano las tuercas sobre la válvula.

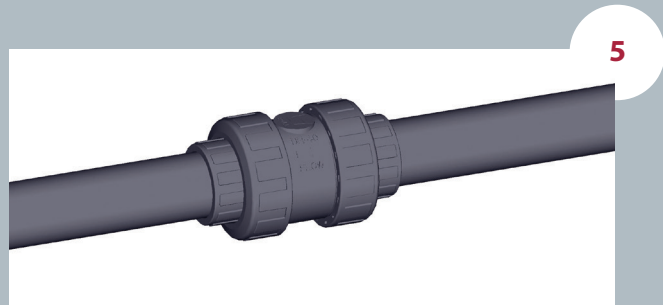
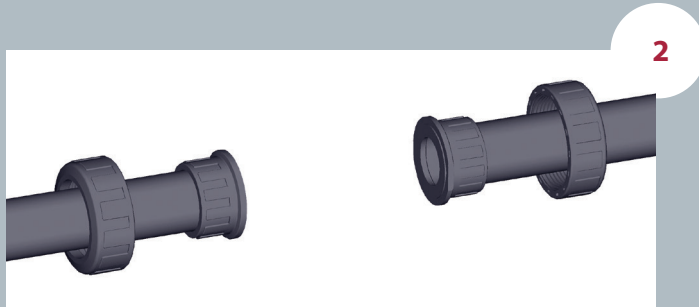
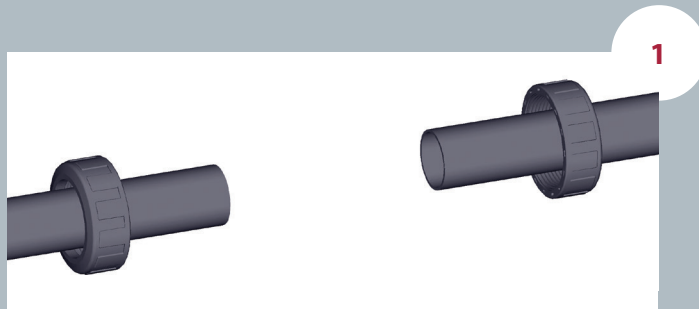

UP-B. 67. SF1 - BALL CHECK VALVE

Ball check valve

- PVC-U body
- Female solvent socket
- Metric series
- O-rings in EPDM

Válvula anti-retorno de bola

- Cuerpo en PVC-U
- Encolar hembra
- Serie métrica
- Anillos tóricos en EPDM

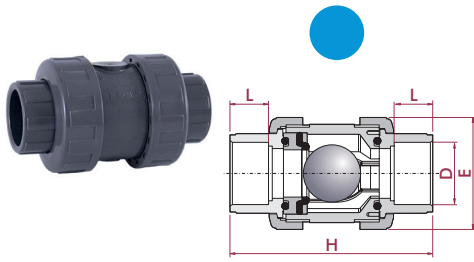

D	DN	PN	REF.	CODE
20	15	16	05 67 220	22078
25	20	16	05 67 225	22079
32	25	16	05 67 232	22080
40	32	16	05 67 240	22174
50	40	16	05 67 250	25697
63	50	16	05 67 263	25698
75	65	10	05 67 275	22175
90	80	10	05 67 290	22176
110	80	10	05 67 310	22177

L	H	E
16	84	52
19	108	62
22	119	70
26	142	84
31	162	94
38	192	117
44	232	148
51	269	179
51	269	179

UP-B. 67. FT1 - BALL CHECK VALVE

Ball check valve

- PVC-U body
- BSP female thread
- O-Rings in EPDM

Válvula anti-retorno de bola

- Cuerpo en PVC-U
- Roscar hembra BSP
- Anillos tóricos en EPDM

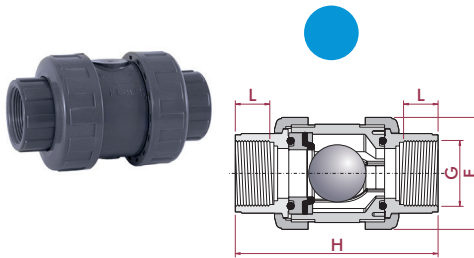

G	DN	PN	REF.	CODE
½"	15	16	05 67 420	22061
¾"	20	16	05 67 425	22062
1"	25	16	05 67 432	22085
1¼"	32	16	05 67 440	22086
1½"	40	16	05 67 450	25699
2"	50	16	05 67 463	25700
2½"	65	10	05 67 475	22087
3"	80	10	05 67 490	22088
4"	80	10	05 67 510	22089

L	H	E
16	84	52
19	108	62
22	119	70
26	142	84
31	167	94
38	192	117
44	232	148
51	269	179
61	279	179

UP-B. 67. SF4 - BALL CHECK VALVE

Ball check valve

- PVC-U body
- Female solvent socket
- Metric series
- O-Rings in FPM

Válvula anti-retorno de bola

- Cuerpo en PVC-U
- Encolar hembra
- Serie métrica
- Anillos tóricos en FPM

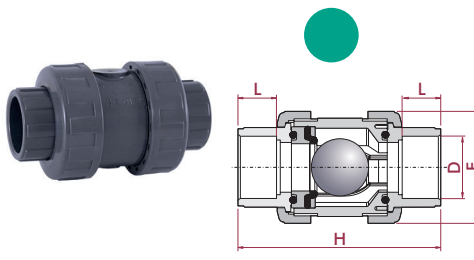

D	DN	PN	REF.	CODE
20	15	16	05 67 220 VI	22090
25	20	16	05 67 225 VI	22091
32	25	16	05 67 232 VI	22092
40	32	16	05 67 240 VI	22239
50	40	16	05 67 250 VI	25701
63	50	16	05 67 263 VI	25702
75	65	10	05 67 275 VI	22240
90	80	10	05 67 290 VI	22241
110	80	10	05 67 310 VI	22242

L	H	E
16	84	52
19	108	62
22	119	70
26	142	84
31	162	94
38	192	117
44	232	148
51	269	179
51	269	179

UP-B. 67. FT4 - BALL CHECK VALVE

Ball check valve

- PVC-U body
- BSP female thread
- O-Rings in FPM

Válvula anti-retorno de bola

- Cuerpo en PVC-U
- Roscar hembra BSP
- Anillos tóricos en FPM

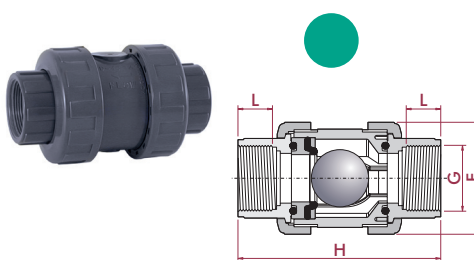

G	DN	PN	REF.	CODE
½"	15	16	05 67 420 VI	22243
¾"	20	16	05 67 425 VI	22244
1"	25	16	05 67 432 VI	22267
1¼"	32	16	05 67 440 VI	22268
1½"	40	16	05 67 450 VI	25703
2"	50	16	05 67 463 VI	25704
2½"	65	10	05 67 475 VI	22269
3"	80	10	05 67 490 VI	22270
4"	80	10	05 67 510 VI	22893

L	H	E
16	84	52
19	108	62
22	119	70
26	142	84
31	167	94
38	192	117
44	232	148
51	269	179
61	279	179

PVC-U CHECK VALVES - BALL SERIES

VÁLVULAS ANTI-RETORNO PVC-U - SERIE BOLA



Sizes	Solvent cement D20 - D110 (DN15 - DN100) Threaded ½" - 4"	
Standards	Solvent socket - Metric, British standard, ASTM, JIS Threaded - BSP, NPT	EN ISO 1452, EN ISO 15493, BS 4346-1, ASTM D 2467, JIS K 6743 ISO 228-1, ASTM D 2464
Working pressure	@ 20°C (73°F) D20-D63 (½" - 2"): PN 16 (240 psi) D75 - D110 (2½" - 4"): PN 10 (150 psi)	
Minimum return pressure	0,2 bar (3 psi) Minimal downstream pressure to keep the valve closed in horizontal position. Presión mínima aguas abajo para mantener la válvula cerrada en caso de instalación horizontal.	
Materials	O-rings: EPDM / FPM	
Characteristics	<ul style="list-style-type: none"> • Completely made in plastic - corrosion free. • 100% factory tested. • Excellent flow rate. • Easy installation and maintenance. • May be used either vertically and horizontally. • Available in PVC-U and Corzan® PVC-C. • Resistance to many inorganic chemicals. • Excellent flow characteristics. 	<ul style="list-style-type: none"> • Fabricada completamente en plástico - libre de corrosión. • Probadas al 100% en fábrica. • Excelente coeficiente de caudal. • Fácil instalación y mantenimiento. • Se pueden usar indistintamente verticalmente o horizontalmente. • Disponibles en PVC-U y Corzan® PVC-C. • Resistencia a múltiples sustancias químicas inorgánicas. • Excelentes características de conducción.
Certifications / regulations	Check valve design regulation - ISO 16137:2006	

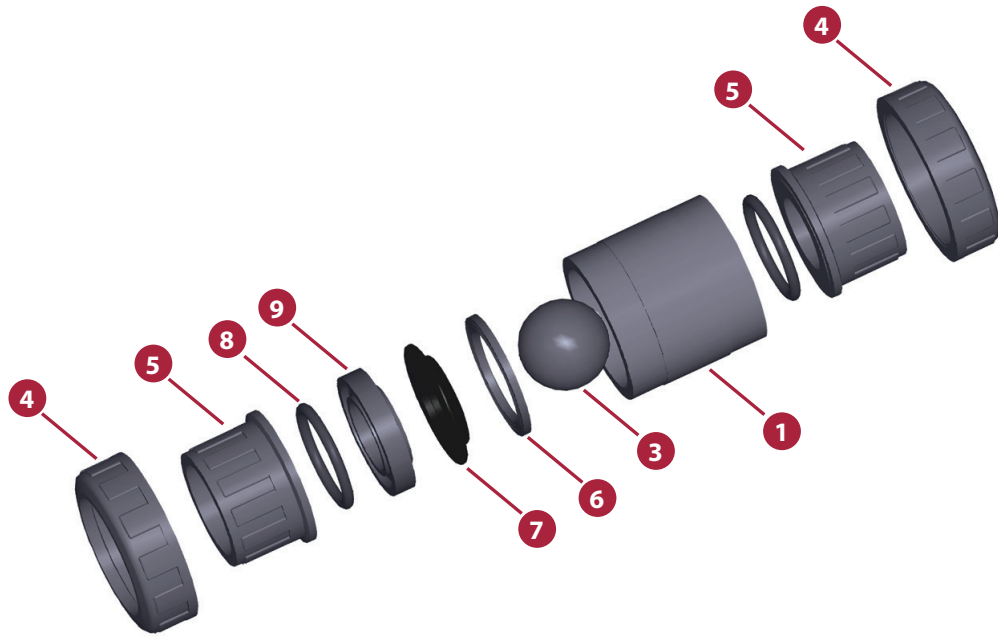
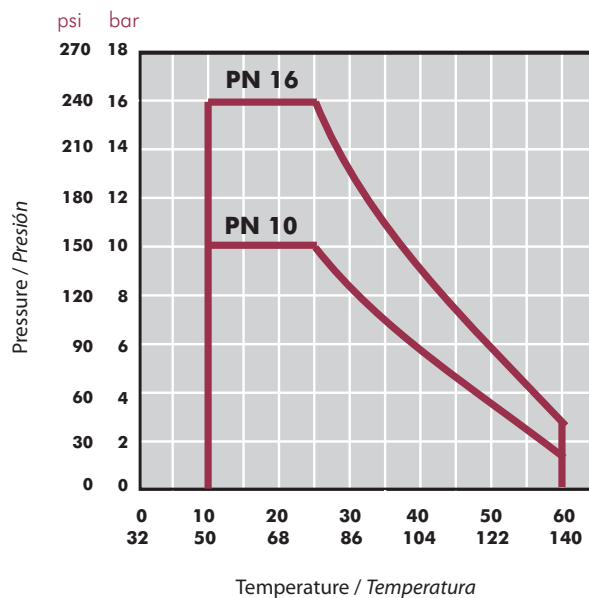

FIG.	Parts	Despiece	Material
1	Body	Cuerpo	PVC-U
3	Ball	Bola	PVC-U
4	Union nut	Tuerca	PVC-U
5	End connector	Manguito enlace	PVC-U
6	Closing ring	Anillo de cierre	PVC-U
7	Body o-ring	Junta cuerpo	EPDM / FPM
8	End connector o-ring	Junta manguito	EPDM / FPM
9	Seal-carrier	Portajuntas	PVC-U

PRESSURE / TEMPERATURE GRAPH
DIAGRAMA PRESIÓN / TEMPERATURA



Life: 25 years
 Hydrostatic maximum pressure a component may withstand in continuous service (without overpressure)

Vida útil: 25 años
 Presión hidrostática máxima que un componente es capaz de soportar en servicio continuo (sin sobrepresión)

PRESSURE LOSS DIAGRAM
DIAGRAMA DE PÉRDIDAS DE CARGA

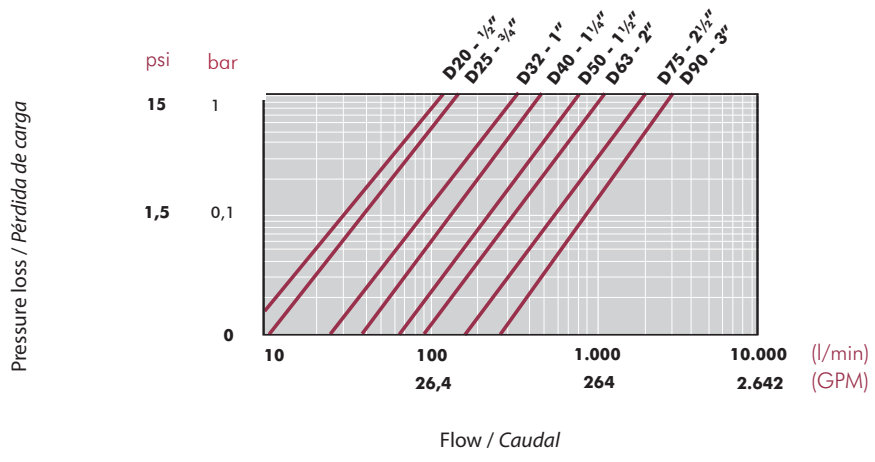

RELATIVE FLOW
FLUJO RELATIVO

D	20-1/2"	25-3/4"	32-1"	40-1 1/4"	50-1 1/2"	63-2"	75-2 1/2"	90-3"
DN	15	20	25	32	40	50	65	80
Kv_{100}	99	128	308	453	795	1040	1932	2754
Cv	7	9	22	32	56	73	135	193

$Cv = Kv_{100} / 14,28$
 Kv_{100} (l/min, $\Delta p = 1$ bar)
 Cv (GPM, $\Delta p = 1$ psi)

Open
Abierto

Closed
Cerrado

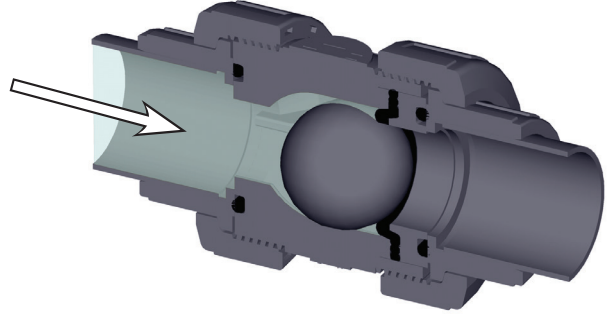
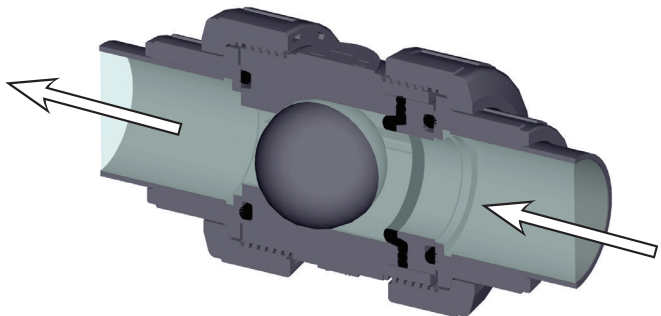

ASSEMBLY INSTRUCTIONS

Solvent socket or threaded unions

Loosen the valve union nuts (4) and separate these and the end connectors (5) from the valve body. Pass the pipe through the nuts and then place the bushes over the end of the pipe. The socket unions should be glued onto the pipe using a PVC-U or PVC-C adhesive and pressure should not be applied to the system until a drying period of at least 1 hour per bar of working pressure has elapsed. In the case of threaded unions, PTFE tape should be applied to the male threads. The pipes can now be attached to the valve by hand tightening down the nuts.

INSTRUCCIONES DE MONTAJE

Uniones encoladas o roscadas

Afloje las tuercas (4) de la válvula y sepárelas de los manguitos (5). Introduzca las tuercas en los tubos y a continuación fije los manguitos en los extremos del tubo. Las uniones encoladas se realizarán con un adhesivo para tubos de PVC-U o PVC-C rígido y no se aplicará presión hasta transcurridas al menos 1 hora por bar. En las uniones roscadas se colocará cinta de PTFE en las roscas macho. A continuación ya podrá colocarse la válvula entre los manguitos y apretar a mano las tuercas sobre la válvula.

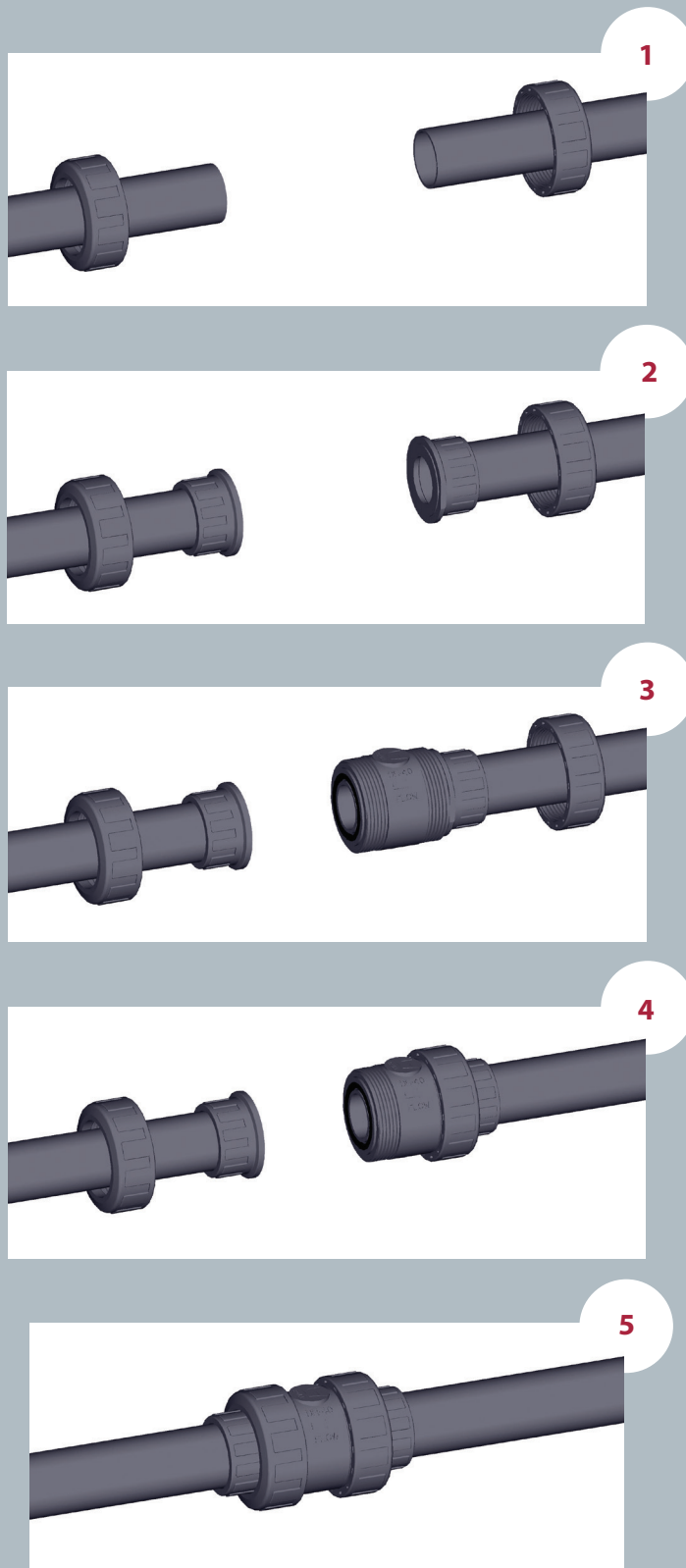

UP-B. **67**. SF1. BS - PVC-U BALL CHECK VALVE

Ball check valve

- PVC-U body
- Female solvent socket
- British Standard series
- O-rings in EPDM

Válvula anti-retorno de bola

- Cuerpo en PVC-U
- Encolar hembra
- Serie British Standard
- Anillos tóricos en EPDM

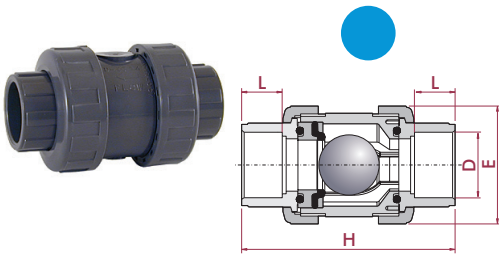

D	DN	PN	REF.	CODE
½"	15	16	05 67 901 E	33010
¾"	20	16	05 67 902 E	33011
1"	25	16	05 67 903 E	33012
1¼"	32	16	05 67 904 E	33013
1½"	40	16	05 67 905 E	33014
2"	50	16	05 67 906 E	33015

L	H	E
16	84	52
19	108	62
22	119	70
26	142	84
31	162	94
38	192	117

 UP-B. **67**. SF4. BS - PVC-U BALL CHECK VALVE

Ball check valve

- PVC-U body
- Female solvent socket
- British Standard series
- O-rings in FPM

Válvula anti-retorno de bola

- Cuerpo en PVC-U
- Encolar hembra
- Serie British Standard
- Anillos tóricos en FPM

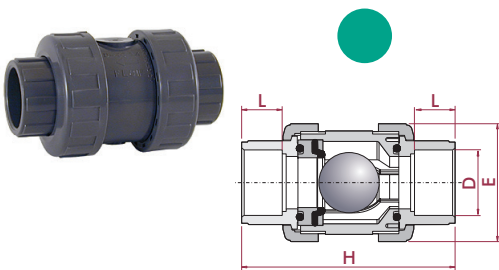

D	DN	PN	REF.	CODE
½"	15	16	05 67 901 VE	33016
¾"	20	16	05 67 902 VE	33017
1"	25	16	05 67 903 VE	33018
1¼"	32	16	05 67 904 VE	33019
1½"	40	16	05 67 905 VE	33020
2"	50	16	05 67 906 VE	33021

L	H	E
16	84	52
19	108	62
22	119	70
26	142	84
31	162	94
38	192	117

PVC-U CHECK VALVES - BALL SERIES

VÁLVULAS ANTI-RETORNO PVC-U - SERIE BOLA



Sizes	Solvent cement D20 - D110 (DN15 - DN100) Threaded ½" - 4"	
Standards	Solvent socket - Metric, British standard, ASTM, JIS Threaded - BSP, NPT	EN ISO 1452, EN ISO 15493, BS 4346-1, ASTM D 2467, JIS K 6743 ISO 228-1, ASTM D 2464
Working pressure	@ 20°C (73°F) D20-D63 (½" - 2"): PN 16 (240 psi) D75 - D110 (2½" - 4"): PN 10 (150 psi)	
Minimum return pressure	0,2 bar (3 psi) Minimal downstream pressure to keep the valve closed in horizontal position. Presión mínima aguas abajo para mantener la válvula cerrada en caso de instalación horizontal.	
Materials	O-rings: EPDM / FPM	
Characteristics	<ul style="list-style-type: none"> • Completely made in plastic - corrosion free. • 100% factory tested. • Excellent flow rate. • Easy installation and maintenance. • May be used either vertically and horizontally. • Available in PVC-U and Corzan® PVC-C. • Resistance to many inorganic chemicals. • Excellent flow characteristics. 	<ul style="list-style-type: none"> • Fabricada completamente en plástico - libre de corrosión. • Probadas al 100% en fábrica. • Excelente coeficiente de caudal. • Fácil instalación y mantenimiento. • Se pueden usar indistintamente verticalmente o horizontalmente. • Disponibles en PVC-U y Corzan® PVC-C. • Resistencia a múltiples sustancias químicas inorgánicas. • Excelentes características de conducción.
Certifications / regulations	Check valve design regulation - ISO 16137:2006	

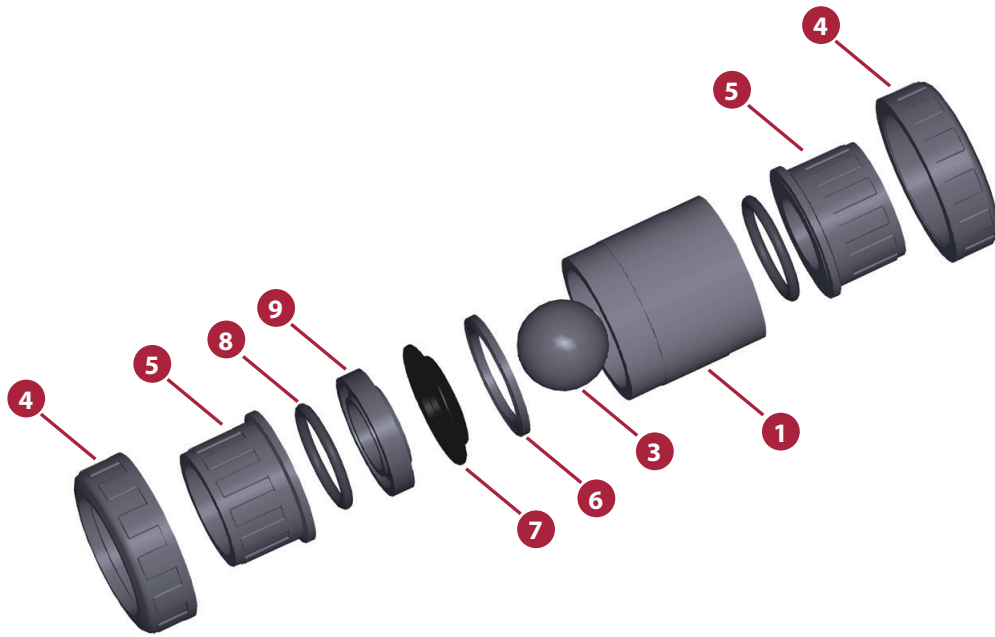
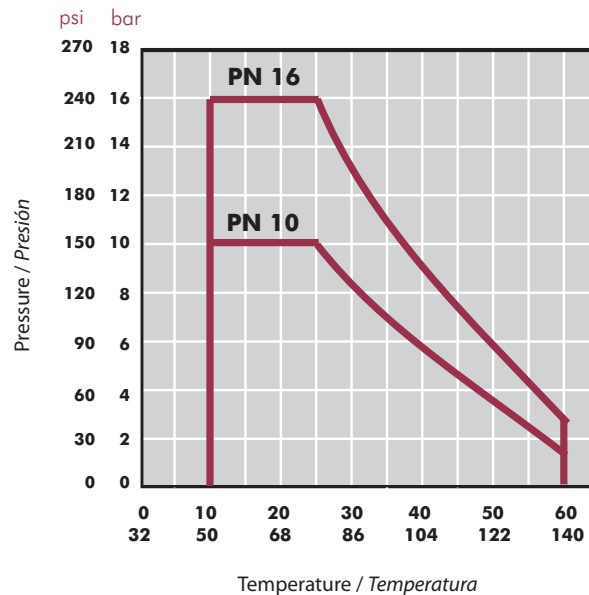

FIG.	Parts	Despiece	Material
1	Body	Cuerpo	PVC-U
3	Ball	Bola	PVC-U
4	Union nut	Tuerca	PVC-U
5	End connector	Manguito enlace	PVC-U
6	Closing ring	Anillo de cierre	PVC-U
7	Body o-ring	Junta cuerpo	EPDM / FPM
8	End connector o-ring	Junta manguito	EPDM / FPM
9	Seal-carrier	Portajuntas	PVC-U

PRESSURE / TEMPERATURE GRAPH
DIAGRAMA PRESIÓN / TEMPERATURA



Life: 25 years
 Hydrostatic maximum pressure a component may withstand in continuous service (without overpressure)

Vida útil: 25 años
 Presión hidrostática máxima que un componente es capaz de soportar en servicio continuo (sin sobrepresión)

PRESSURE LOSS DIAGRAM
DIAGRAMA DE PÉRDIDAS DE CARGA

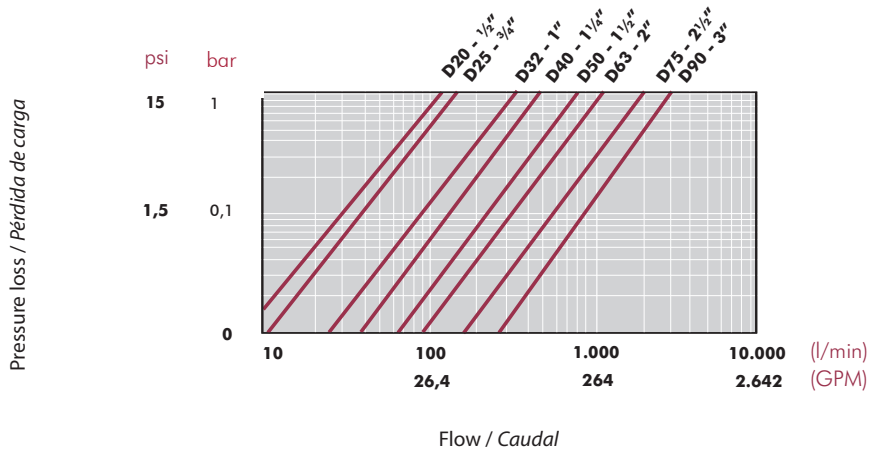

RELATIVE FLOW
FLUJO RELATIVO

D	20-1/2"	25-3/4"	32-1"	40-1 1/4"	50-1 1/2"	63-2"	75-2 1/2"	90-3"
DN	15	20	25	32	40	50	65	80
Kv₁₀₀	99	128	308	453	795	1040	1932	2754
Cv	7	9	22	32	56	73	135	193

$Cv = Kv_{100} / 14,28$
 Kv_{100} (l/min, $\Delta p = 1$ bar)
 Cv (GPM, $\Delta p = 1$ psi)

Open
Abierto

Closed
Cerrado

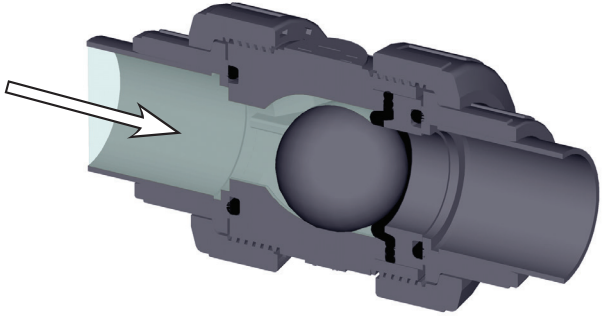
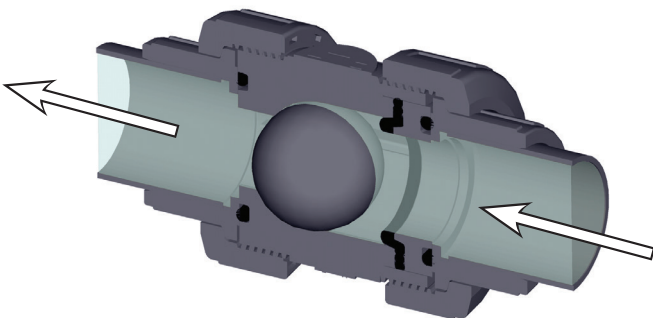

ASSEMBLY INSTRUCTIONS

Solvent socket or threaded unions

Loosen the valve union nuts (4) and separate these and the end connectors (5) from the valve body. Pass the pipe through the nuts and then place the bushes over the end of the pipe. The socket unions should be glued onto the pipe using a PVC-U or PVC-C adhesive and pressure should not be applied to the system until a drying period of at least 1 hour per bar of working pressure has elapsed. In the case of threaded unions, PTFE tape should be applied to the male threads. The pipes can now be attached to the valve by hand tightening down the nuts.

INSTRUCCIONES DE MONTAJE

Uniones encoladas o roscadas

Afloje las tuercas (4) de la válvula y sepárelas de los manguitos (5). Introduzca las tuercas en los tubos y a continuación fije los manguitos en los extremos del tubo. Las uniones encoladas se realizarán con un adhesivo para tubos de PVC-U o PVC-C rígido y no se aplicará presión hasta transcurridas al menos 1 hora por bar. En las uniones roscadas se colocará cinta de PTFE en las roscas macho. A continuación ya podrá colocarse la válvula entre los manguitos y apretar a mano las tuercas sobre la válvula.

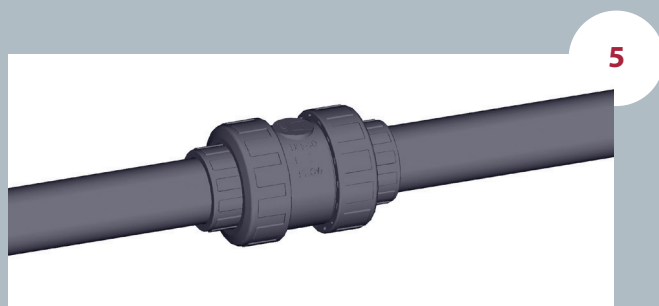
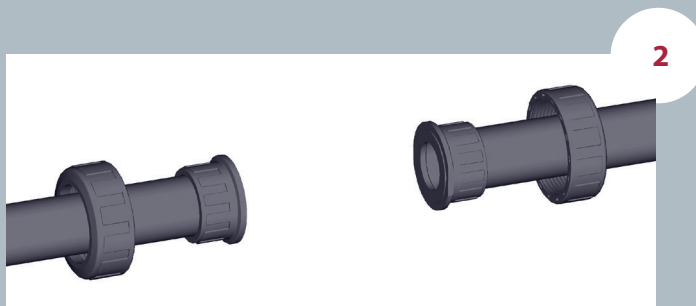
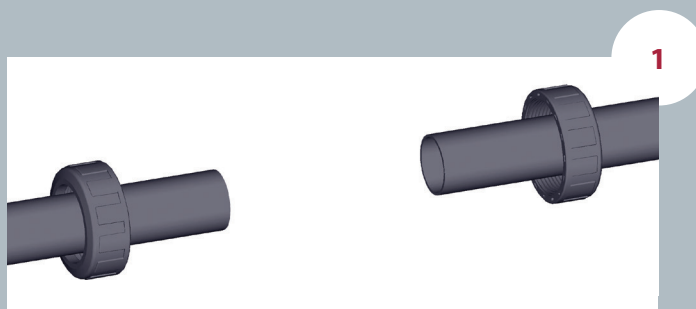

UP-B. 67. SF1. MA - PVC-U BALL CHECK VALVE

Ball check valve

- PVC-U body
- Female solvent socket
- ASTM series
- O-rings in EPDM

Válvula anti-retorno de bola

- Cuerpo en PVC-U
- Encolar hembra
- Serie ASTM
- Anillos tóricos en EPDM

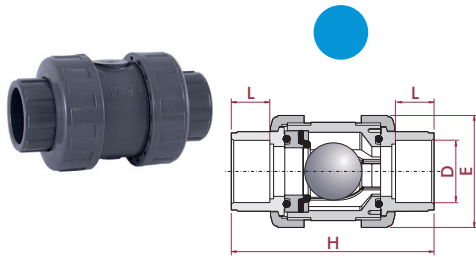

D	DN	PN	REF.	CODE
½"	15	16	05 67 901 EMA	41380
¾"	20	16	05 67 902 EMA	41381
1"	25	16	05 67 903 EMA	41382
1¼"	32	16	05 67 904 EMA	41383
1½"	40	16	05 67 905 EMA	41384
2"	50	16	05 67 906 EMA	41385
2½"	65	10	05 67 907 EMA	41386
3"	80	10	05 67 908 EMA	41387
4"	80	10	05 67 910 EMA	41388

L	H	E
16	84	52
19	108	62
22	119	70
26	142	84
31	162	94
38	192	117
44	232	148
51	269	179
51	269	179

UP-B. 67. FT1. MA - PVC-U BALL CHECK VALVE

Ball check valve

- PVC-U body
- NPT female thread
- O-Rings in EPDM

Válvula anti-retorno de bola

- Cuerpo en PVC-U
- Roscar hembra NPT
- Anillos tóricos en EPDM

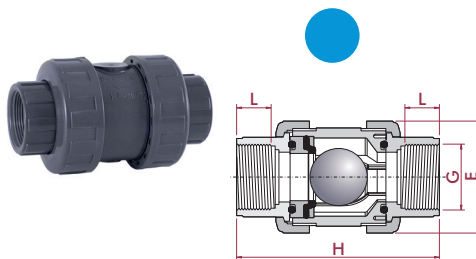

G	DN	PN	REF.	CODE
½"	15	16	05 67 801 E	41389
¾"	20	16	05 67 802 E	41390
1"	25	16	05 67 803 E	41391
1¼"	32	16	05 67 804 E	41392
1½"	40	16	05 67 805 E	41393
2"	50	16	05 67 806 E	41394
2½"	65	10	05 67 807 E	41395
3"	80	10	05 67 808 E	41396
4"	80	10	05 67 810 E	41397

L	H	E
16	84	52
19	108	62
22	119	70
26	142	84
31	167	94
38	192	117
44	232	148
51	269	179
61	279	179

UP-B. **67**. SF1. MA - PVC-U BALL CHECK VALVE COMBO

Ball check valve

- PVC-U body
- Female solvent socket
- ASTM series
- O-rings in EPDM

Válvula anti-retorno de bola

- Cuerpo en PVC-U
- Encolar hembra
- Serie ASTM
- Anillos tóricos en EPDM

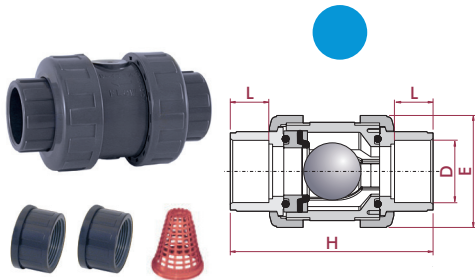

D	DN	PN	REF.	CODE
½"	15	16	05 67 801 ED *	27360
¾"	20	16	05 67 802 ED *	27361
1"	25	16	05 67 803 ED *	27362
1¼"	32	16	05 67 804 ED *	27363
1½"	40	16	05 67 805 ED *	27000
2"	50	16	05 67 806 ED *	27001
2½"	65	10	05 67 907 EMAR *	27374
3"	80	10	05 67 908 EMAR *	27375
4"	80	10	05 67 910 EMAR *	27376

L	H	E
16	84	52
19	108	62
22	119	70
26	142	84
31	162	94
38	192	117
44	232	148
51	269	179
51	269	179

UP-B. **67**. FT1. MA - PVC-U BALL CHECK VALVE COMBO

Ball check valve

- PVC-U body
- NPT female thread
- O-Rings in EPDM

Válvula anti-retorno de bola

- Cuerpo en PVC-U
- Roscar hembra NPT
- Anillos tóricos en EPDM

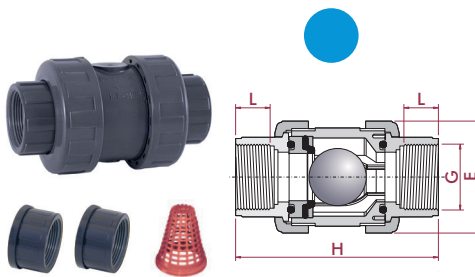

G	DN	PN	REF.	CODE
½"	15	16	05 67 801 ED *	27360
¾"	20	16	05 67 802 ED *	27361
1"	25	16	05 67 803 ED *	27362
1¼"	32	16	05 67 804 ED *	27363
1½"	40	16	05 67 805 ED *	27000
2"	50	16	05 67 806 ED *	27001
2½"	65	10	05 67 807 ER *	27368
3"	80	10	05 67 808 ER *	27369
4"	80	10	05 67 810 ER *	27370

L	H	E
16	84	52
19	108	62
22	119	70
26	142	84
31	167	94
38	192	117
44	232	148
51	269	179
61	279	179

COMBO VERSION

- 1½" - 2": valve with solvent socket unions + spare threaded unions in the same box
- 2½" - 4": only solvent sokcet or threaded unions assembled including the grid for transforming the check valve in foot valve

VERSIÓN COMBO

- 1½" - 2": manguitos enlace encolar montados + manguitos enlace roscar añadidos en caja
- 2½" - 4": sólo manguitos enlace encolar o roscar e incluyen rejilla para transformación en válvula de pie

UP-B. 67. SF4. MA - PVC-U BALL CHECK VALVE

Ball check valve

- PVC-U body
- Female solvent socket
- ASTM series
- O-Rings in FPM

Válvula anti-retorno de bola

- Cuerpo en PVC-U
- Encolar hembra
- Serie ASTM
- Anillos tóricos en FPM

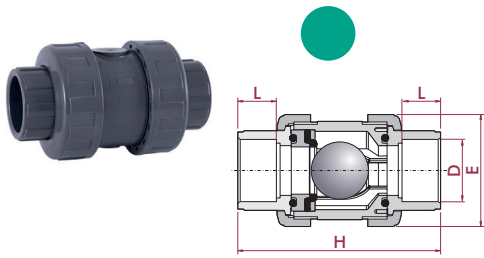

D	DN	PN	REF.	CODE
½"	15	16	05 67 901 VEMA	41962
¾"	20	16	05 67 902 VEMA	41963
1"	25	16	05 67 903 VEMA	41964
1¼"	32	16	05 67 904 VEMA	41965
1½"	40	16	05 67 905 VEMA	41966
2"	50	16	05 67 906 VEMA	41967
2½"	65	10	05 67 907 VEMA	41968
3"	80	10	05 67 908 VEMA	41969
4"	80	10	05 67 910 VEMA	41970

L	H	E
16	84	52
19	108	62
22	119	70
26	142	84
31	162	94
38	192	117
44	232	148
51	269	179
51	269	179

UP-B. 67. SF4. MA - PVC-U BALL CHECK VALVE COMBO

Ball check valve

- PVC-U body
- Female solvent socket
- ASTM series
- O-Rings in FPM

Válvula anti-retorno de bola

- Cuerpo en PVC-U
- Encolar hembra
- Serie ASTM
- Anillos tóricos en FPM

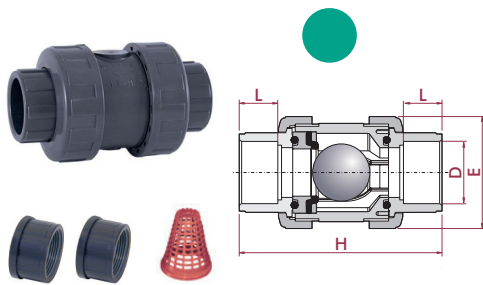

D	DN	PN	REF.	CODE
½"	15	16	05 67 801 VED *	27364
¾"	20	16	05 67 802 VED *	27365
1"	25	16	05 67 803 VED *	27366
1¼"	32	16	05 67 804 VED *	27367
1½"	40	16	05 67 805 VED *	27002
2"	50	16	05 67 806 VED *	27003
2½"	65	10	05 67 907 VEMAR *	27377
3"	80	10	05 67 908 VEMAR *	27378
4"	80	10	05 67 910 VEMAR *	27379

L	H	E
16	84	52
19	108	62
22	119	70
26	142	84
31	162	94
38	192	117
44	232	148
51	269	179
51	269	179

UP-B. 67. FT4. MA - PVC-U BALL CHECK VALVE COMBO

Ball check valve

- PVC-U body
- NPT female thread
- O-Rings in FPM

Válvula anti-retorno de bola

- Cuerpo en PVC-U
- Roscar hembra NPT
- Anillos tóricos en FPM

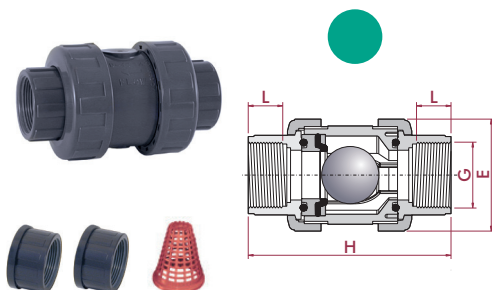

G	DN	PN	REF.	CODE
½"	15	16	05 67 801 VED *	27364
¾"	20	16	05 67 802 VED *	27365
1"	25	16	05 67 803 VED *	27366
1¼"	32	16	05 67 804 VED *	27367
1½"	40	16	05 67 805 VED *	27002
2"	50	16	05 67 806 VED *	27003
2½"	65	10	05 67 807 VER *	27371
3"	80	10	05 67 808 VER *	27372
4"	80	10	05 67 810 VER *	27373

L	H	E
16	84	52
19	108	62
22	119	70
26	142	84
31	167	94
38	192	117
44	232	148
51	269	179
61	279	179

COMBO VERSION

- 1½" - 2": valve with solvent socket unions + spare threaded unions in the same box
- 2½" - 4": only solvent sokcet or threaded unions assembled including the grid for transforming the check valve in foot valve

VERSIÓN COMBO

- 1½" - 2": manguitos enlace encolar montados + manguitos enlace roscar añadidos en caja
- 2½" - 4": sólo manguitos enlace encolar o roscar e incluyen rejilla para transformación en válvula de pie

PVC-C CHECK VALVES - BALL SERIES

VÁLVULAS ANTI-RETORNO PVC-C - SERIE BOLA



Sizes	Solvent cement D20 - D110 (DN15 - DN100) Threaded ½" - 4"	
Standards	Solvent socket - Metric, British standard, ASTM, JIS Threaded - BSP, NPT	EN ISO 1452, EN ISO 15493, BS 4346-1, ASTM D 2467, JIS K 6743 ISO 228-1, ASTM D 2464
Working pressure	@ 20°C (73°F) D20-D63 (½" - 2"): PN 16 (240 psi) D75 - D110 (2½" - 4"): PN 10 (150 psi)	
Minimum return pressure	0,2 bar (3 psi) Minimal downstream pressure to keep the valve closed in horizontal position. Presión mínima aguas abajo para mantener la válvula cerrada en caso de instalación horizontal.	
Materials	O-rings: EPDM / FPM	
Characteristics	<ul style="list-style-type: none"> • Completely made in plastic - corrosion free. • 100% factory tested. • Excellent flow rate. • Easy installation and maintenance. • May be used either vertically and horizontally. • Available in PVC-U and Corzan® PVC-C. • Resistance to many inorganic chemicals. • Excellent flow characteristics. 	<ul style="list-style-type: none"> • Fabricada completamente en plástico - libre de corrosión. • Probadas al 100% en fábrica. • Excelente coeficiente de caudal. • Fácil instalación y mantenimiento. • Se pueden usar indistintamente verticalmente o horizontalmente. • Disponibles en PVC-U y Corzan® PVC-C. • Resistencia a múltiples sustancias químicas inorgánicas. • Excelentes características de conducción.
Certifications / regulations	Check valve design regulation - ISO 16137:2006	

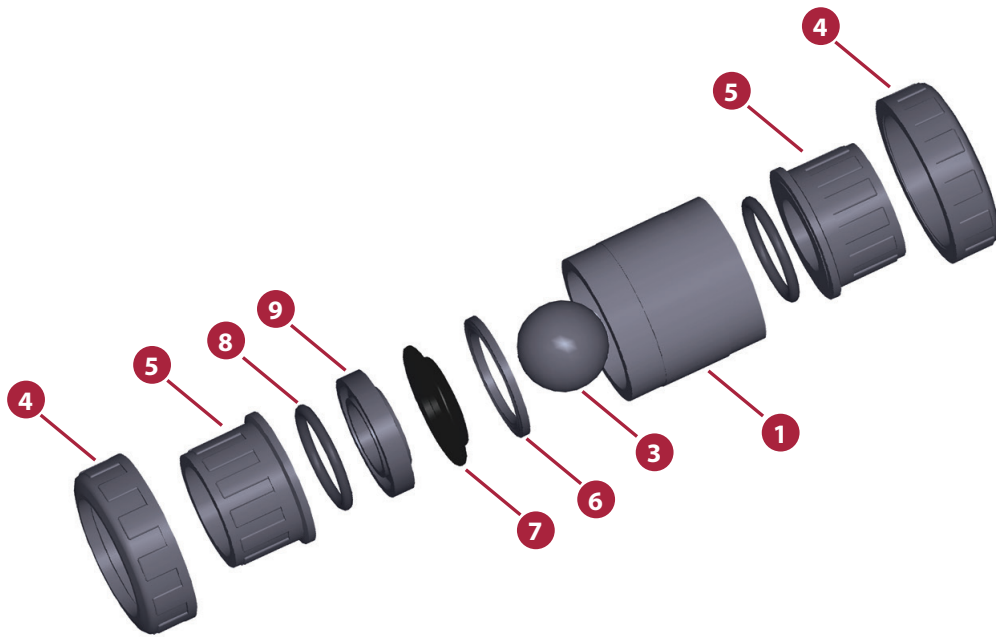
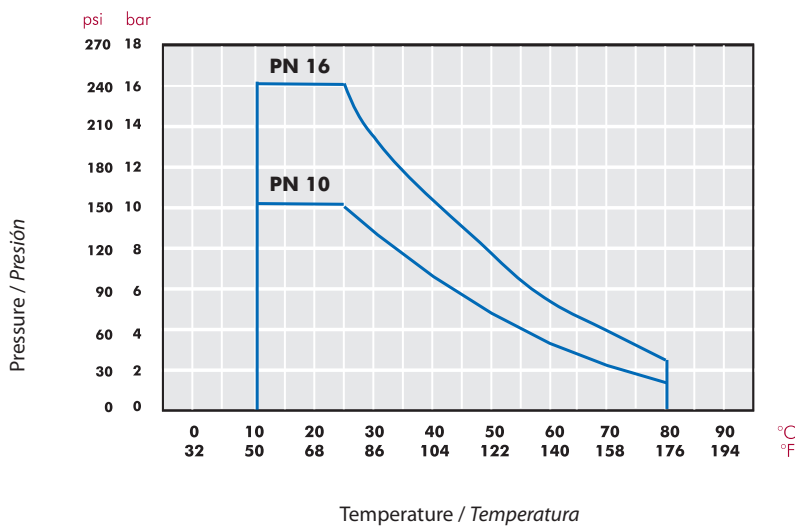

FIG.	Parts	Despiece	Material
1	Body	Cuerpo	PVC-C
3	Ball	Bola	PVC-C
4	Union nut	Tuerca	PVC-C
5	End connector	Manguito enlace	PVC-C
6	Closing ring	Anillo de cierre	PVC-C
7	Body o-ring	Junta cuerpo	EPDM / FPM
8	End connector o-ring	Junta manguito	EPDM / FPM
9	Seal-carrier	Portajuntas	PVC-C

PRESSURE / TEMPERATURE GRAPH
DIAGRAMA PRESIÓN / TEMPERATURA



Life: 25 years
 Hydrostatic maximum pressure a component may withstand in continuous service (without overpressure)

Vida útil: 25 años
 Presión hidrostática máxima que un componente es capaz de soportar en servicio continuo (sin sobrepresión)

PRESSURE LOSS DIAGRAM
DIAGRAMA DE PÉRDIDAS DE CARGA

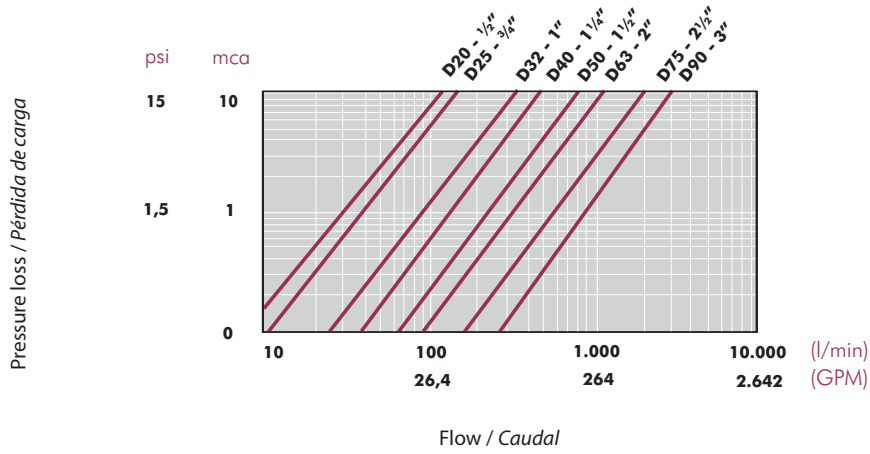

RELATIVE FLOW
FLUJO RELATIVO

D	20-1/2"	25-3/4"	32-1"	40-1 1/4"	50-1 1/2"	63-2"	75-2 1/2"	90-3"
DN	15	20	25	32	40	50	65	80
Kv_{100}	99	128	308	453	795	1040	1932	2754
Cv	7	9	22	32	56	73	135	193

$Cv = Kv_{100} / 14,28$
 Kv_{100} (l/min, $\Delta p = 1$ bar)
 Cv (GPM, $\Delta p = 1$ psi)

Open
Abierto

Closed
Cerrado

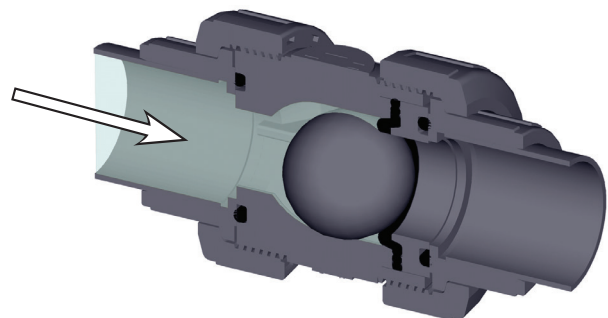
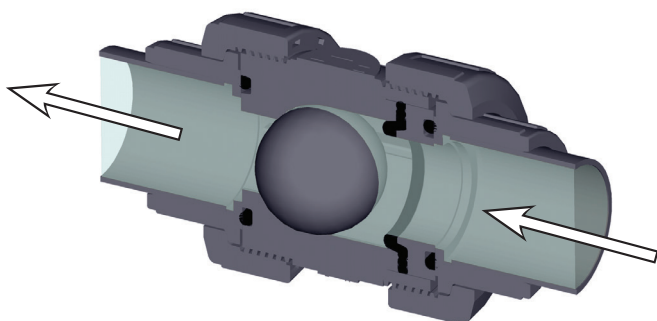

ASSEMBLY INSTRUCTIONS

Solvent socket or threaded unions

Loosen the valve union nuts (4) and separate these and the end connectors (5) from the valve body. Pass the pipe through the nuts and then place the bushes over the end of the pipe. The socket unions should be glued onto the pipe using a PVC-U or PVC-C adhesive and pressure should not be applied to the system until a drying period of at least 1 hour per bar of working pressure has elapsed. In the case of threaded unions, PTFE tape should be applied to the male threads. The pipes can now be attached to the valve by hand tightening down the nuts.

INSTRUCCIONES DE MONTAJE

Uniones encoladas o roscadas

Afloje las tuercas (4) de la válvula y sepárelas de los manguitos (5). Introduzca las tuercas en los tubos y a continuación fije los manguitos en los extremos del tubo. Las uniones encoladas se realizarán con un adhesivo para tubos de PVC-U o PVC-C rígido y no se aplicará presión hasta transcurridas al menos 1 hora por bar. En las uniones roscadas se colocará cinta de PTFE en las roscas macho. A continuación ya podrá colocarse la válvula entre los manguitos y apretar a mano las tuercas sobre la válvula.

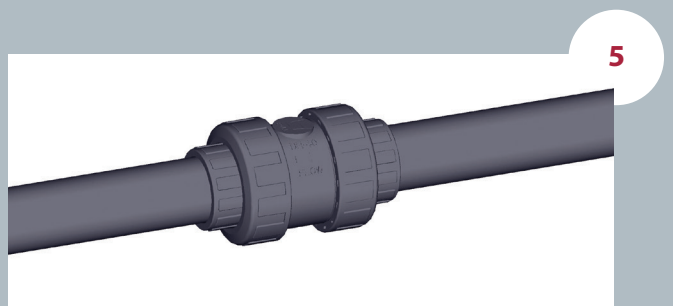
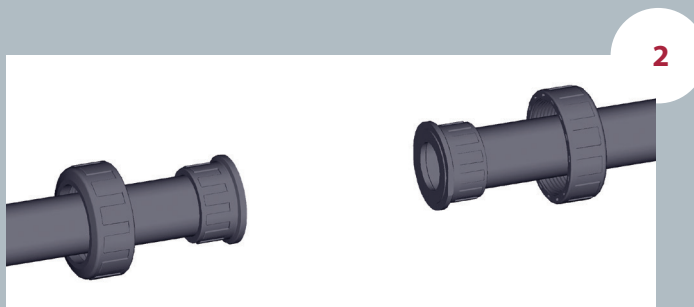
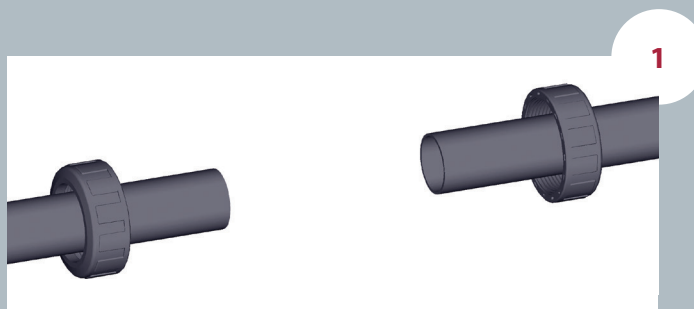

CP-B. 67. SF1 - PVC-C BALL CHECK VALVE
Ball check valve

- Corzan® PVC-C body
- Female solvent socket
- Metric series
- O-Rings in EPDM

Válvula anti-retorno de bola

- Cuerpo en Corzan® PVC-C
- Encolar hembra
- Serie métrica
- Anillos tóricos en EPDM

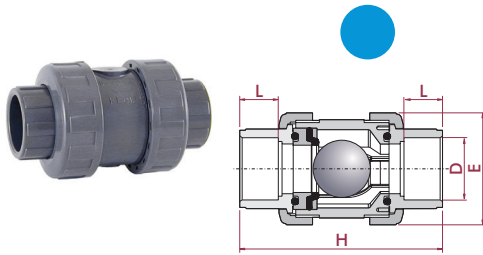

D	DN	PN	REF.	CODE
20	15	16	35 67 220	27501
25	20	16	35 67 225	27502
32	25	16	35 67 232	27503
40	32	16	35 67 240	27504
50	40	16	35 67 250	27505
63	50	16	35 67 263	27506
75	65	10	35 67 275	27507
90	80	10	35 67 290	27508
110	80	10	35 67 310	27509

L	H	E
16	84	52
19	108	62
22	119	70
26	142	84
31	162	94
38	192	117
44	232	148
51	269	179
51	269	179

CP-B. 67. FT1 - PVC-C BALL CHECK VALVE
Ball check valve

- Corzan® PVC-C body
- BSP female thread
- O-Rings in EPDM

Válvula anti-retorno de bola

- Cuerpo en Corzan® PVC-C
- Roscar hembra BSP
- Anillos tóricos en EPDM

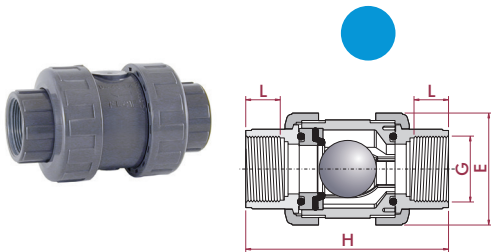

G	DN	PN	REF.	CODE
½"	15	16	35 67 420	27510
¾"	20	16	35 67 425	27511
1"	25	16	35 67 432	27512
1¼"	32	16	35 67 440	27513
1½"	40	16	35 67 450	27514
2"	50	16	35 67 463	27515
2½"	65	10	35 67 475	27516
3"	80	10	35 67 490	27517
4"	80	10	35 67 510	27518

L	H	E
16	84	52
19	108	62
22	119	70
26	142	84
31	162	94
38	192	117
44	232	148
51	269	179
51	269	179

CP-B. 67. SF4 - PVC-C BALL CHECK VALVE
Ball check valve

- Corzan® PVC-C body
- Female solvent socket
- Metric series
- O-Rings in FPM

Válvula anti-retorno de bola

- Cuerpo en Corzan® PVC-C
- Encolar hembra
- Serie métrica
- Anillos tóricos en FPM

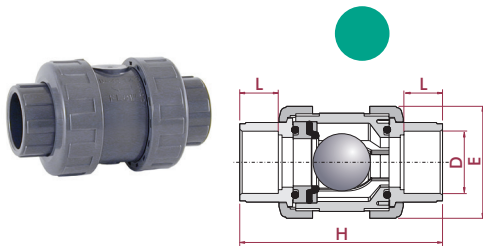

D	DN	PN	REF.	CODE
20	15	16	35 67 220 VI	27519
25	20	16	35 67 225 VI	27520
32	25	16	35 67 232 VI	27521
40	32	16	35 67 240 VI	27522
50	40	16	35 67 250 VI	27523
63	50	16	35 67 263 VI	27524
75	65	10	35 67 275 VI	27525
90	80	10	35 67 290 VI	27526
110	80	10	35 67 310 VI	27527

L	H	E
16	84	52
19	108	62
22	119	70
26	142	84
31	162	94
38	192	117
44	232	148
51	269	179
51	269	179

CP-B. 67. FT4 - PVC-C BALL CHECK VALVE
Ball check valve

- Corzan® PVC-C body
- BSP female thread
- O-Rings in FPM

Válvula anti-retorno de bola

- Cuerpo en Corzan® PVC-C
- Roscar hembra BSP
- Anillos tóricos en FPM

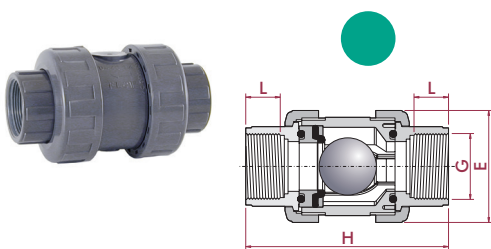

G	DN	PN	REF.	CODE
½"	15	16	35 67 420 VI	27528
¾"	20	16	35 67 425 VI	27529
1"	25	16	35 67 432 VI	27530
1¼"	32	16	35 67 440 VI	27531
1½"	40	16	35 67 450 VI	27532
2"	50	16	35 67 463 VI	27533
2½"	65	10	35 67 475 VI	27534
3"	80	10	35 67 490 VI	27535
4"	80	10	35 67 510 VI	27536

L	H	E
16	84	52
19	108	62
22	119	70
26	142	84
31	162	94
38	192	117
44	232	148
51	269	179
51	269	179

PVC-C CHECK VALVES - BALL SERIES

VÁLVULAS ANTI-RETORNO PVC-C - SERIE BOLA



Sizes	Solvent cement D20 - D110 (DN15 - DN100) Threaded ½" - 4"	
Standards	Solvent socket - Metric, British standard, ASTM, JIS Threaded - BSP, NPT	EN ISO 1452, EN ISO 15493, BS 4346-1, ASTM D 2467, JIS K 6743 ISO 228-1, ASTM D 2464
Working pressure	@ 20°C (73°F) D20-D63 (½" - 2"): PN 16 (240 psi) D75 - D110 (2½" - 4"): PN 10 (150 psi)	
Minimum return pressure	0,2 bar (3 psi) Minimal downstream pressure to keep the valve closed in horizontal position. Presión mínima aguas abajo para mantener la válvula cerrada en caso de instalación horizontal.	
Materials	O-rings: EPDM / FPM	
Characteristics	<ul style="list-style-type: none"> • Completely made in plastic - corrosion free. • 100% factory tested. • Excellent flow rate. • Easy installation and maintenance. • May be used either vertically and horizontally. • Available in PVC-U and Corzan® PVC-C. • Resistance to many inorganic chemicals. • Excellent flow characteristics. 	<ul style="list-style-type: none"> • Fabricada completamente en plástico - libre de corrosión. • Probadas al 100% en fábrica. • Excelente coeficiente de caudal. • Fácil instalación y mantenimiento. • Se pueden usar indistintamente verticalmente o horizontalmente. • Disponibles en PVC-U y Corzan® PVC-C. • Resistencia a múltiples sustancias químicas inorgánicas. • Excelentes características de conducción.
Certifications / regulations	Check valve design regulation - ISO 16137:2006	

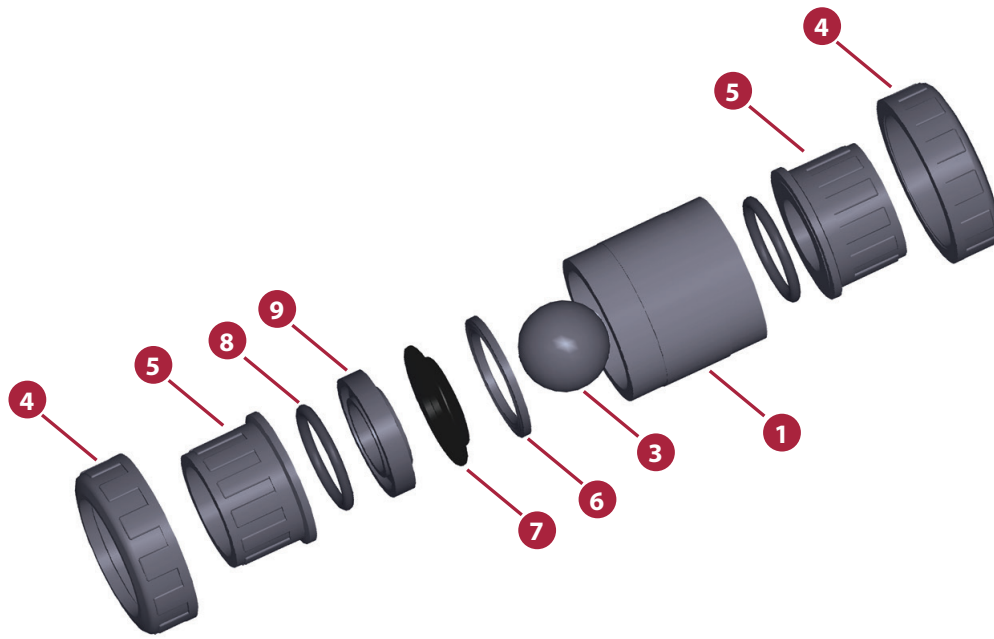
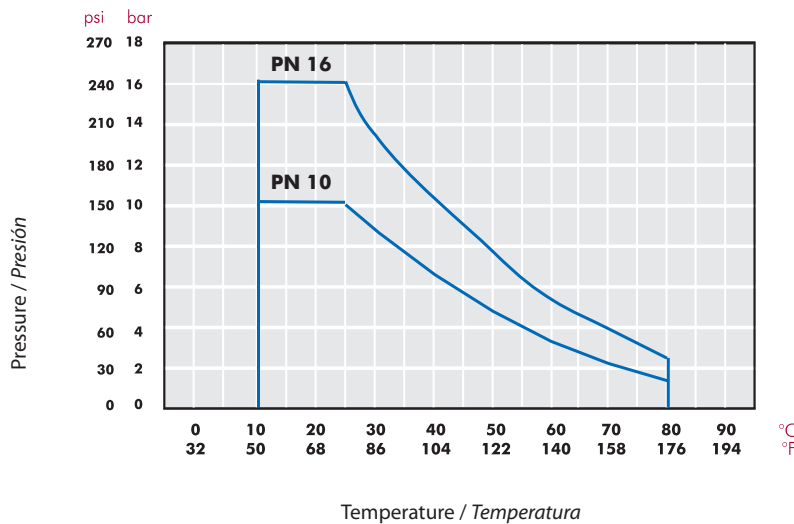

FIG.	Parts	Despiece	Material
1	Body	Cuerpo	PVC-C
3	Ball	Bola	PVC-C
4	Union nut	Tuerca	PVC-C
5	End connector	Manguito enlace	PVC-C
6	Closing ring	Anillo de cierre	PVC-C
7	Body o-ring	Junta cuerpo	EPDM / FPM
8	End connector o-ring	Junta manguito	EPDM / FPM
9	Seal-carrier	Portajuntas	PVC-C

PRESSURE / TEMPERATURE GRAPH
DIAGRAMA PRESIÓN / TEMPERATURA



Life: 25 years
Hydrostatic maximum pressure a component may withstand in continuous service (without overpressure)

Vida útil: 25 años
Presión hidrostática máxima que un componente es capaz de soportar en servicio continuo (sin sobrepresión)

PRESSURE LOSS DIAGRAM
DIAGRAMA DE PÉRDIDAS DE CARGA

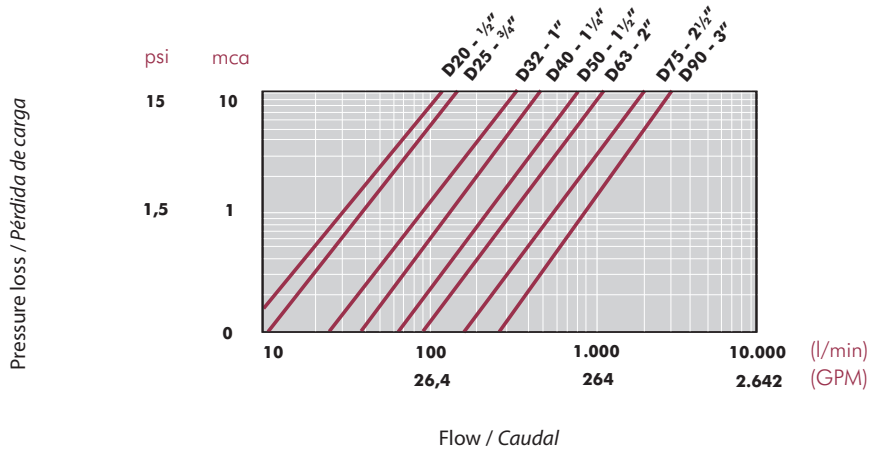

RELATIVE FLOW
FLUJO RELATIVO

D	20-1/2"	25-3/4"	32-1"	40-1 1/4"	50-1 1/2"	63-2"	75-2 1/2"	90-3"
DN	15	20	25	32	40	50	65	80
Kv_{100}	99	128	308	453	795	1040	1932	2754
Cv	7	9	22	32	56	73	135	193

$Cv = Kv_{100} / 14,28$
 Kv_{100} (l/min, $\Delta p = 1$ bar)
 Cv (GPM, $\Delta p = 1$ psi)

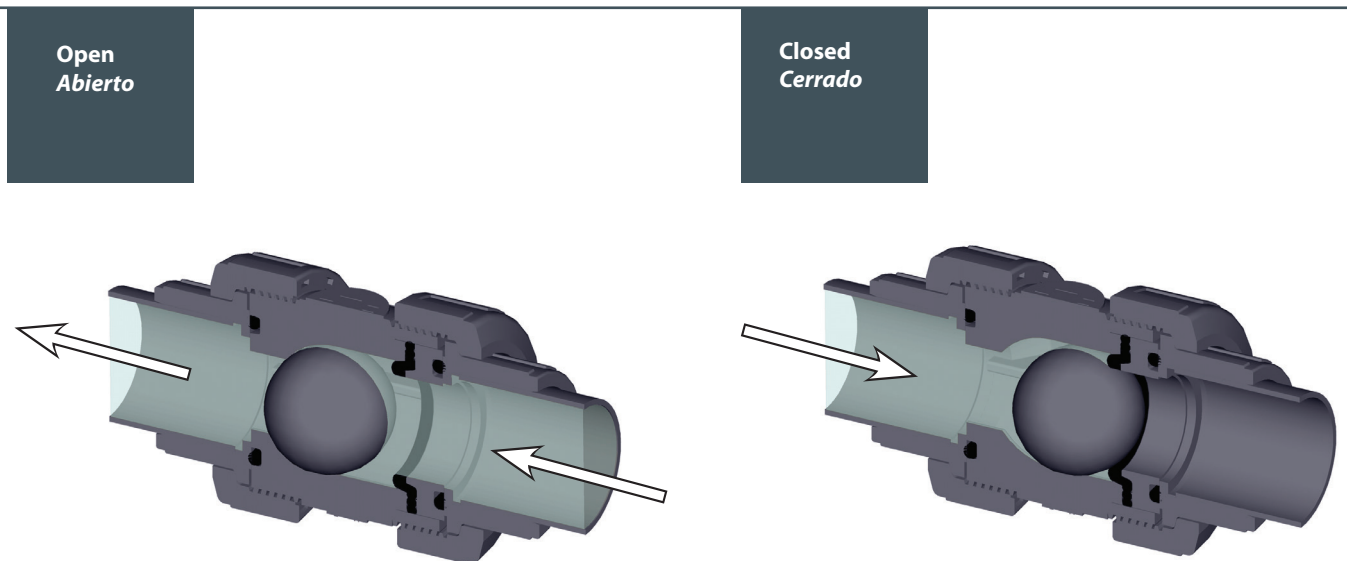

ASSEMBLY INSTRUCTIONS

Solvent socket or threaded unions

Loosen the valve union nuts (4) and separate these and the end connectors (5) from the valve body. Pass the pipe through the nuts and then place the bushes over the end of the pipe. The socket unions should be glued onto the pipe using a PVC-U or PVC-C adhesive and pressure should not be applied to the system until a drying period of at least 1 hour per bar of working pressure has elapsed. In the case of threaded unions, PTFE tape should be applied to the male threads. The pipes can now be attached to the valve by hand tightening down the nuts.

INSTRUCCIONES DE MONTAJE

Uniones encoladas o roscadas

Afloje las tuercas (4) de la válvula y sepárelas de los manguitos (5). Introduzca las tuercas en los tubos y a continuación fije los manguitos en los extremos del tubo. Las uniones encoladas se realizarán con un adhesivo para tubos de PVC-U o PVC-C rígido y no se aplicará presión hasta transcurridas al menos 1 hora por bar. En las uniones roscadas se colocará cinta de PTFE en las roscas macho. A continuación ya podrá colocarse la válvula entre los manguitos y apretar a mano las tuercas sobre la válvula.

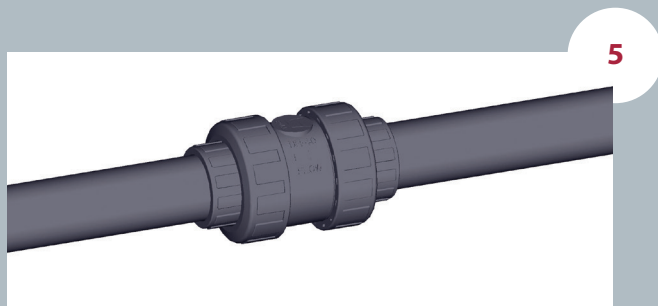
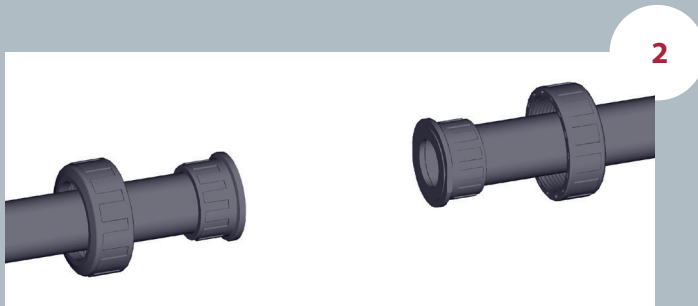
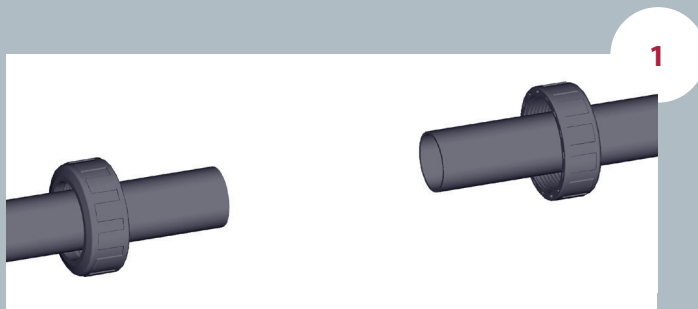

CP-B. 67. SF1. MA - PVC-C BALL CHECK VALVE

Ball check valve

- Corzan® PVC-C body
- Female solvent socket
- ASTM series
- O-Rings in EPDM

Válvula anti-retorno de bola

- Cuerpo en Corzan® PVC-C
- Encolar hembra
- Serie ASTM
- Anillos tóricos en EPDM

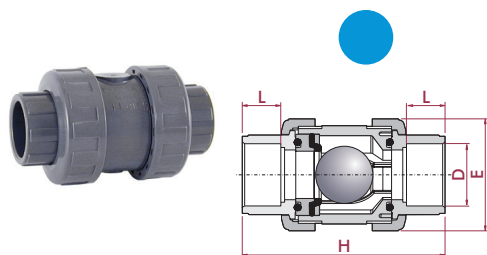

D	DN	PN	REF.	CODE
½"	15	16		
¾"	20	16	35 67 902 EMA	69180
1"	25	16	35 67 903 EMA	61272
1¼"	32	16	35 67 904 EMA	61273
1½"	40	16	35 67 905 EMA	72451
2"	50	16	35 67 906 EMA	67374
2½"	65	10		
3"	80	10	35 67 908 EMA	72589
4"	80	10		

L	H	E
16	84	52
19	108	62
22	119	70
26	142	84
31	162	94
38	192	117
44	232	148
51	269	179
51	269	179

CP-B. 67. SF1. MA - PVC-C BALL CHECK VALVE COMBO

Ball check valve

- Corzan® PVC-C body
- Female solvent socket
- ASTM series
- O-Rings in EPDM

Válvula anti-retorno de bola

- Cuerpo en Corzan® PVC-C
- Encolar hembra
- Serie ASTM
- Anillos tóricos en EPDM

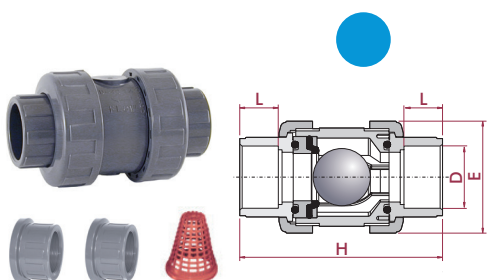

D	DN	PN	REF.	CODE
½"	15	16	35 67 801 ED *	27380
¾"	20	16	35 67 802 ED *	27381
1"	25	16	35 67 803 ED *	27382
1¼"	32	16	35 67 804 ED *	27383
1½"	40	16	35 67 805 ED *	27384
2"	50	16	35 67 806 ED *	27385
2½"	65	10	35 67 907 EMAR *	27397
3"	80	10	35 67 908 EMAR *	27398
4"	80	10	35 67 910 EMAR *	27433

L	H	E
16	84	52
19	108	62
22	119	70
26	142	84
31	162	94
38	192	117
44	232	148
51	269	179
51	269	179

CP-B. 67. FT1. MA - PVC-C BALL CHECK VALVE COMBO

Ball check valve

- Corzan® PVC-C body
- NPT female thread
- O-Rings in EPDM

Válvula anti-retorno de bola

- Cuerpo en Corzan® PVC-C
- Roscar hembra NPT
- Anillos tóricos en EPDM

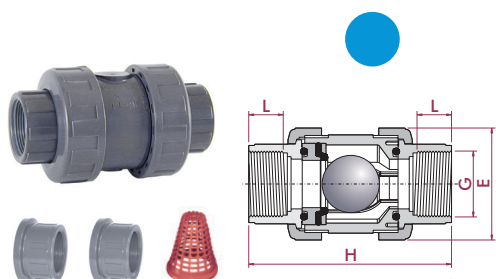

G	DN	PN	REF.	CODE
½"	15	16	35 67 801 ED *	27380
¾"	20	16	35 67 802 ED *	27381
1"	25	16	35 67 803 ED *	27382
1¼"	32	16	35 67 804 ED *	27383
1½"	40	16	35 67 805 ED *	27384
2"	50	16	35 67 806 ED *	27385
2½"	65	10	35 67 807 ER *	27392
3"	80	10	35 67 808 ER *	27393
4"	80	10	35 67 810 ER *	27432

L	H	E
16	84	52
19	108	62
22	119	70
26	142	84
31	162	94
38	192	117
44	232	148
51	269	179
51	269	179

COMBO VERSION

- 1½" - 2": valve with solvent socket unions + spare threaded unions in the same box
- 2½" - 4": only solvent socket or threaded unions assembled including the grid for transforming the check valve in foot valve

VERSIÓN COMBO

- 1½" - 2": manguitos enlace encolar montados + manguitos enlace rosca añadidos en caja
- 2½" - 4": sólo manguitos enlace encolar o rosca e incluyen rejilla para transformación en válvula de pie

CP-B. 67. SF4. MA - PVC-C BALL CHECK VALVE
Ball check valve

- Corzan® PVC-C body
- Female solvent socket
- ASTM series
- O-Rings in FPM

Válvula anti-retorno de bola

- Cuerpo en Corzan® PVC-C
- Encolar hembra
- Serie ASTM
- Anillos tóricos en FPM



D	DN	PN	REF.	CODE
½"	15	16	35 67 901 EAV	69135
¾"	20	16	35 67 902 EAV	69136
1"	25	16	35 67 903 EAV	69137
1¼"	32	16	35 67 904 EAV	69138
1½"	40	16	35 67 905 EAV	69139
2"	50	16	35 67 906 EAV	69140
2½"	65	10	35 67 907 EAV	71978
3"	80	10	35 67 908 EAV	71979
4"	80	10	35 67 910 EAV	71980

L	H	E
16	84	52
19	108	62
22	119	70
26	142	84
31	162	94
38	192	117
44	232	148
51	269	179
51	269	179

CP-B. 67. SF4. MA - PVC-C BALL CHECK VALVE COMBO
Ball check valve

- Corzan® PVC-C body
- Female solvent socket
- ASTM series
- O-Rings in FPM

Válvula anti-retorno de bola

- Cuerpo en Corzan® PVC-C
- Encolar hembra
- Serie ASTM
- Anillos tóricos en FPM

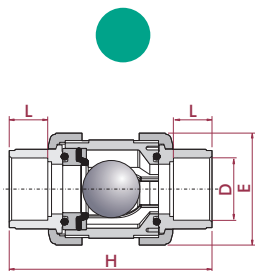

D	DN	PN	REF.	CODE
½"	15	16	35 67 801 VED *	27386
¾"	20	16	35 67 802 VED *	27387
1"	25	16	35 67 803 VED *	27388
1¼"	32	16	35 67 804 VED *	27389
1½"	40	16	35 67 805 VED *	27390
2"	50	16	35 67 806 VED *	27391
2½"	65	10	35 67 907 VEMAR *	27399
3"	80	10	35 67 908 VEMAR *	27400
4"	80	10	35 67 910 VEMAR *	27401

L	H	E
16	84	52
19	108	62
22	119	70
26	142	84
31	162	94
38	192	117
44	232	148
51	269	179
51	269	179

CP-B. 67. FT4. MA - PVC-C BALL CHECK VALVE COMBO
Ball check valve

- Corzan® PVC-C body
- NPT female thread
- O-Rings in FPM

Válvula anti-retorno de bola

- Cuerpo en Corzan® PVC-C
- Roscar hembra NPT
- Anillos tóricos en FPM

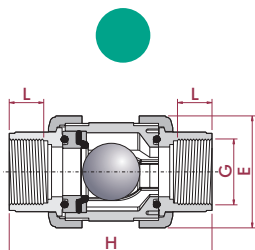

G	DN	PN	REF.	CODE
½"	15	16	35 67 801 VED *	27386
¾"	20	16	35 67 802 VED *	27387
1"	25	16	35 67 803 VED *	27388
1¼"	32	16	35 67 804 VED *	27389
1½"	40	16	35 67 805 VED *	27390
2"	50	16	35 67 806 VED *	27391
2½"	65	10	35 67 807 VER *	27394
3"	80	10	35 67 808 VER *	27395
4"	80	10	35 67 810 VER *	27396

L	H	E
16	84	52
19	108	62
22	119	70
26	142	84
31	162	94
38	192	117
44	232	148
51	269	179
51	269	179

COMBO VERSION

- 1½" - 2": valve with solvent socket unions + spare threaded unions in the same box
- 2½" - 4": only solvent socket or threaded unions assembled including the grid for transforming the check valve in foot valve

VERSIÓN COMBO

- 1½" - 2": manguitos enlace encolar montados + manguitos enlace rosca añadidos en caja
- 2½" - 4": sólo manguitos enlace encolar o rosca e incluyen rejilla para transformación en válvula de pie